

## 650ml Kraft BioBoard Takeaway Base BB-LB-650-N

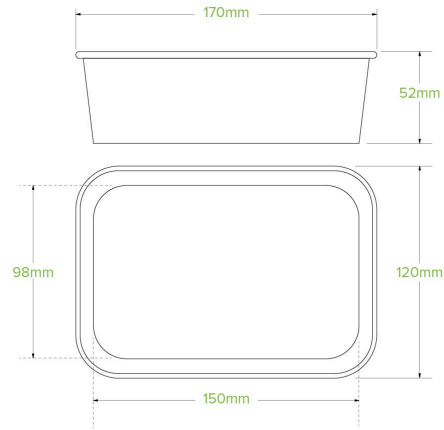

650ml Natural BioBoard Rectangular Paper Containers are sustainably sourced and made from FSC™ certified paper board. They are lined with a bioplastic made from plants, not oil. These food containers are perfect for hot and greasy food. Certified industrially compostable.

<b>Carton quantity:</b> 300	<b>Sleeves per carton:</b> 6	<b>Units per sleeve:</b> 50
<b>Carton Size LxWxH (cm):</b> 38x36x45.5	<b>Carton gross weight (kg):</b> 6.000000	<b>Carton barcode:</b> 19344062067662
<b>Raw Material:</b> Paper - FSC™ Mix certified paper	<b>Lining/coating:</b> Bioplastic - PLA	<b>Window Material:</b> None
<b>Printing Type:</b> Flexo	<b>Inks:</b> Food Contact Safe Inks	<b>Brim fill capacity (ml):</b> 660
<b>Dimensions top LxW (mm):</b> 172x120	<b>Dimensions base LxW (mm):</b> 150x98	<b>Product Depth:</b> 51
<b>Thickness:</b> 350gsm	<b>Use:</b> Hot, Cold, Wet & Dry Products	<b>Manufactured:</b> China
<b>Customise:</b> Print	<b>MOQ custom:</b> 50000	<b>Mould fees:</b> Yes - see custom packaging
<b>Home compostable:</b> No	<b>Industrially compostable:</b> Certified to AS4736 Australian Standards, Certified to EN13432 European Standard	<b>Recyclable:</b> No